

LP® SHED ASSEMBLY INSTRUCTIONS | WALNUT HILL 8'x12' GABLE ROOF SHED



1. Refer to Walnut Hill 8'x12' Gable Roof Shed plans for actual lumber dimensions and details.
2. Refer to lpshed.com for additional application and installation details to help build your shed.



Shed images are for illustrative purposes only.

Louisiana-Pacific Corporation (LP) has provided the shed designs described as a general guide to those who are interested in building sheds or in having a shed built. We do not claim that the designs or that the materials we describe are correct or the only options you have. LP has prepared each design in an attempt to satisfy generally accepted building rules and regulations. However, the designs were created without any knowledge of local conditions or geographic variables. Specific soil conditions, snow loads, wind loads, frost depth and materials will vary and may require modifications. LP cannot assure that the structures made using our designs meet your local conditions or local building code requirements. Local laws may require a permit. You are responsible for verifying that the design you choose conforms to your local building code. We strongly recommend that you: (a) contact a licensed contractor for detailed plans and construction advice; (b) contact a local building official to verify that the design meets your code requirements; and (c) check your neighborhood covenants before starting a shed project so that you can determine the appropriate size, location and approvals needed for a shed. LP is not responsible for changes made to a design. LP does not perform construction supervision and is not responsible for verifying that construction conforms to a design. LP is not responsible for how the construction work is performed including methods, sequences, techniques or procedures of construction. LP is not responsible for site safety.

LP makes no representations or warranties of any kind, express or implied, relating to the completeness, accuracy, reliability, suitability or availability of the designs or materials shown here. Without limiting the prior sentence, we specifically disclaim the implied warranties of merchantability and fitness for a particular purpose to the extent allowed under applicable state laws. Any reliance you place on the information in this plan is at your own risk.

You agree that LP will not be liable for any loss, damage or injury arising from the use of the designs and the materials described in this plan, whether such loss, damage or injury is claimed to be directly, indirectly, consequentially or incidentally caused by LP. You agree and acknowledge that the sole and exclusive remedy of any such claim, including attorneys' fees and costs, shall not exceed \$100.00.

BEFORE YOU START

MATERIALS LIST

	MINIMUM QUANTITY	DESCRIPTION
<input type="checkbox"/>	6	8x8x16 cmu blocks
<input type="checkbox"/>	30	2x4x8' wall studs
<input type="checkbox"/>	4	4x4x8' corner posts
<input type="checkbox"/>	16	2x6x8' roof rafters
<input type="checkbox"/>	1	2x10x8' ridge beam
<input type="checkbox"/>	12	2x4x8' studs for horizontal/vertical blocking
<input type="checkbox"/>	12	2x4x10' studs for top & bottom plates
<input type="checkbox"/>	12	2x6x8' floor joists
<input type="checkbox"/>	2	2x6x12' rim joists for floor joist members
<input type="checkbox"/>	2	6x6x12' platform beams
<input type="checkbox"/>	8	2x4x4' studs for vertical gable end wall studs
<input type="checkbox"/>	50 lf	Metal flashing
<input type="checkbox"/>	3	2'-0"x3'-0" windows (by Owner)
<input type="checkbox"/>	1 pair	2'-0"x6'-8" doors (by Owner)
<input type="checkbox"/>	96 sf	LP® ProStruct® floor panels*
<input type="checkbox"/>	230 sf	LP® SmartSide® siding panels
<input type="checkbox"/>	210 sf	LP® ProStruct® Roof Sheathing with SilverTech®**
<input type="checkbox"/>	230 lf	1x4 LP® SmartSide® trim boards
<input type="checkbox"/>	210 sf	Roofing material (by Owner)

HARDWARE LIST

	MINIMUM QUANTITY	DESCRIPTION
<input type="checkbox"/>	8	Angle brackets for 6x6 platform beams
<input type="checkbox"/>	150	Screws for platform flooring
<input type="checkbox"/>	400	Nails for wood stud wall framing
<input type="checkbox"/>	400	Nails for wall panel siding and trim
<input type="checkbox"/>	200	Nails for roof panels
<input type="checkbox"/>		Door and window hardware by Owner

*If this product is unavailable, you can substitute LP® TopNotch® Sub-Flooring.

**If this product is unavailable, you can substitute LP® TechShield® Radiant Barrier Sheathing or LP® OSB sheathing.

FOUNDATION

1. Most buildings of less than 120 square feet do not require a building permit from the local building department, but be sure to check with your local authorities before starting construction.
2. Contact your local building department to locate existing underground utility lines for you. You don't want to disturb or hit any lines while preparing your foundation.
3. Refer to the LP website lpshed.com/advice/buildshedfoundation for more detailed instruction on how to prep and ready your site for the shed foundation. Important: The shed needs to sit on a stable/level surface, enabling the doors to work properly.
4. The shed floor also needs to sit at least 6" above the surrounding ground, for proper rainwater drainage and to prevent the shed from absorbing any standing rainwater.

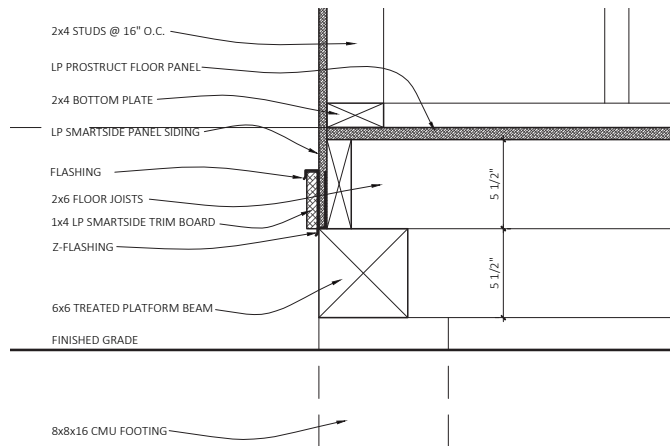

4 Detail

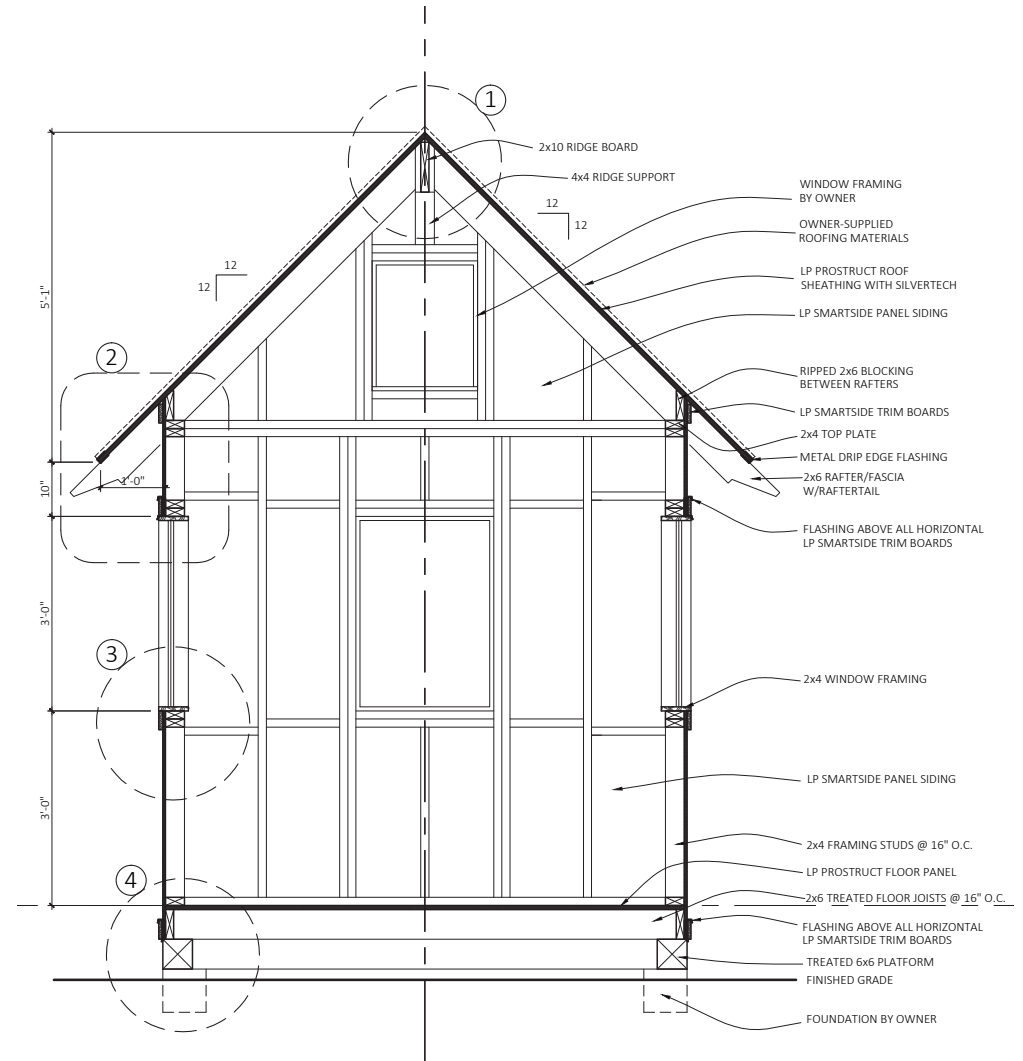

Cross-Section

SHED PLATFORM/FLOORING

1. Lay out the perimeter of the shed, either with a stringline or with stakes marking the corners.
2. This shed will rest on an assembly of 6x6 and 2x6 wood framing members.
3. Install (6) 8"x8"x16" concrete masonry units (cmu's) at the corners and mid-span of the 12' length of 6x6 platform. Be sure the cmu's are level and straight in line with the overall dimensions of this 8'x12' shed.
4. Lay the 6x6's across the 3 cmu's on each side of the shed. Test and adjust as needed for levelness and squareness. To achieve squareness, measure diagonally from corner to opposite corner of the 6x6's. You can adjust this as you build the platform.
5. Cut and install the 2x6 floor joists at 16" on center, attach to the 6x6's with lag bolts and washers or with joist hangers. Adjust the diagonal measurements until they are equal. The platform framing will then be square.
6. Install sheets of LP® ProStruct® floor panels following the LP ProStruct Flooring installation instructions found at lpcorp.com/resources/product-literature. Be sure to stagger the seams between floor panels so 4 corners of 4 panels do not meet.

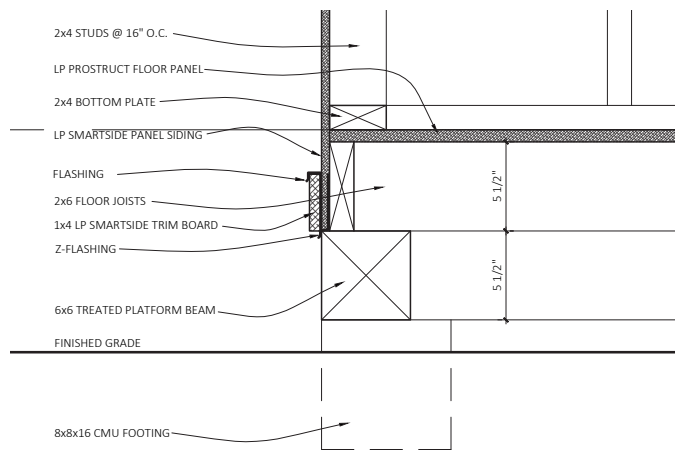

4 Detail

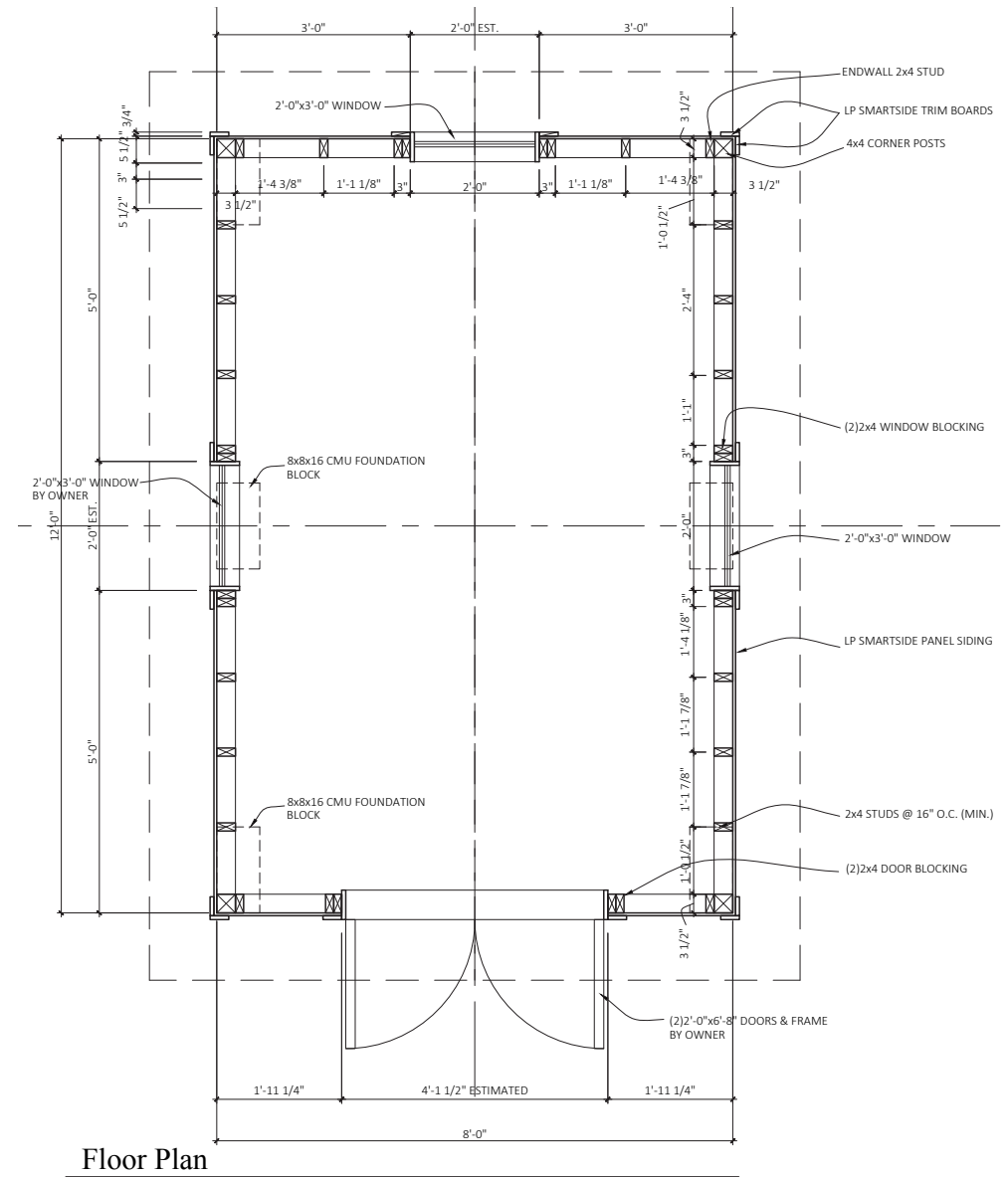

Floor Plan

WALLS

1. Lay out the (2) 4x4 corner posts and 2x4 studs (at 16" on center) on the shed floor. Use the shed floor as a guide to constructing your walls, since the floor is level and square.
2. When framing window and door openings, use 2 2x4 studs on each side of the openings.
3. Secure the ends of the posts and studs with 2x4 top and bottom stud plates at each end. Drive screws through these top and bottom plates into the posts and studs to hold them in place. We will be adding a second top plate member after all walls are erected.
4. Install the horizontal cross bracing/blocking between the studs with 2x4's cut to length.
5. Continuously measure the wall to be sure it is square.
6. After the studs and corner posts are secured to the top and bottom plates, raise the wall into place on the shed floor. Attach 2x4 diagonal bracing to the top of the wall at each end. Use a level to determine that the corner posts are perfectly plumb and vertically square. Once square, screw the diagonal brace to the outside face of the platform to hold the wall in place.
7. Construct the remaining 3 walls in a similar fashion, making sure to frame properly for all appropriate openings in the walls. Allow the shorter 8' end walls to rest within the corner posts. Temporarily hold these walls in place with diagonal bracing.
8. Before continuing, re-measure all corners and walls, making sure all are level and plumb as needed.
9. Attach 2x4 top plates to the tops of the wall assembly. Overlap the joints where the walls come together with the top plates. Continue installation of these top plates all around the perimeter of the walls.

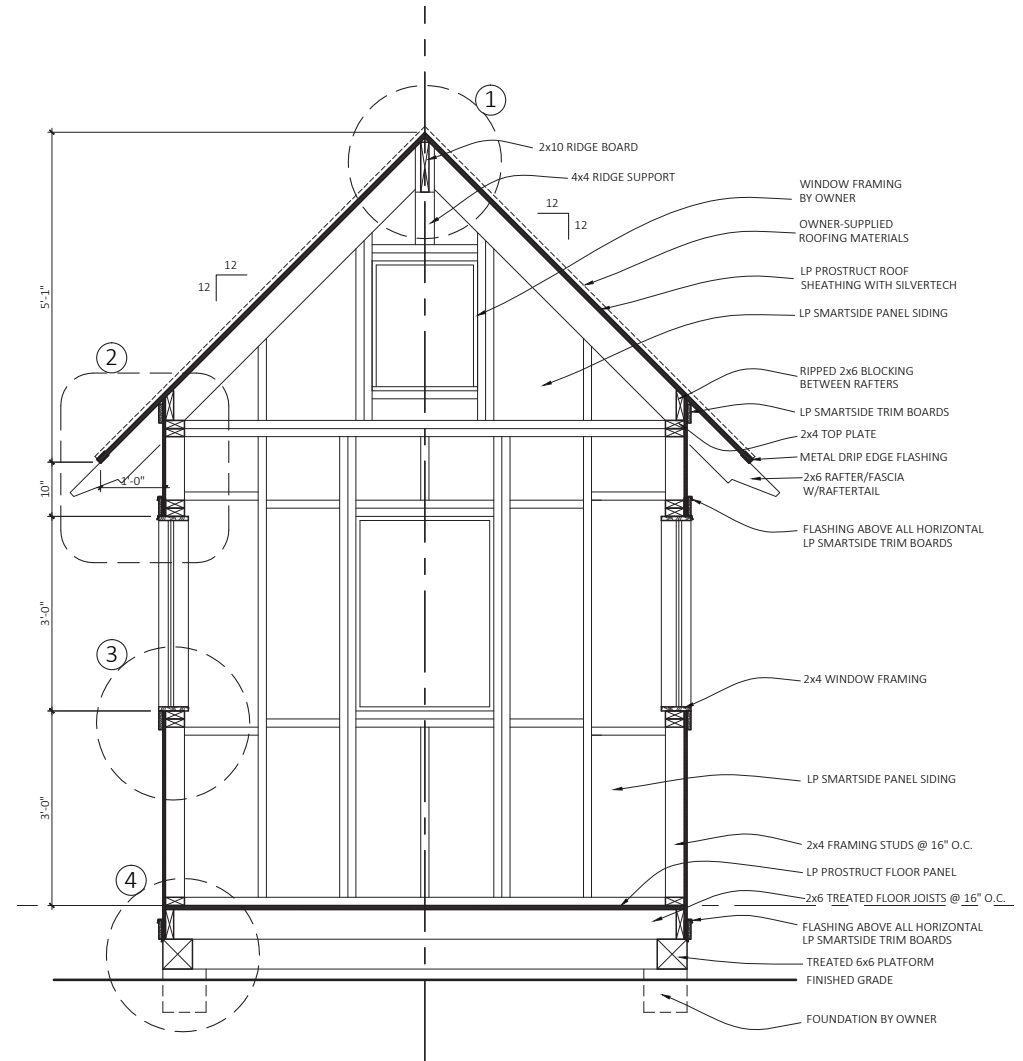

Cross-Section

ROOF RAFTERS

1. The rafters meet at the top and are secured to the 2x10 ridge beam. You will have to temporarily brace the ridge beam at the height required. Use a piece of 4x4 to support the ridge beam.
2. The 2x6 roof rafters have small notches ("birds-mouth") cut into them which allow them to sit on the top plates of the walls. Cut out these notches on the dimensions shown on the Details in the shed plan. Make another angle cut at the end of the rafter to fit onto the ridge beam. Refer to the Details on the shed plan for these dimensions. Use a power saw to cut the majority of the rafters, and finish the cuts with a handsaw.
3. If the bottom end of the rafter shows a decorative "raftertail," cut out according to the Details on the shed plan.
4. Make 2 roof rafters. Test-fit them on the walls and ridge beam. Adjust and re-cut as needed for a tight fit. Once a good fit is established, these rafters will act as a template for the remaining rafters. Simply place this rafter template on the remaining 2x6's, mark and cut as needed. But, it's always good practice to test-fit as you go.
5. Once all the rafters are cut, mark their locations on the tops of the walls. Refer to the drawings for locations of rafters and outlookers members.
6. Start the assembly by setting pairs of rafters at the ends of the building. Adjust the ridge beam as needed so all are straight, level and plumb. Then, install the remaining rafters, making sure all fits are tight. Attach with screws angled through the rafters into the top plates of the walls.

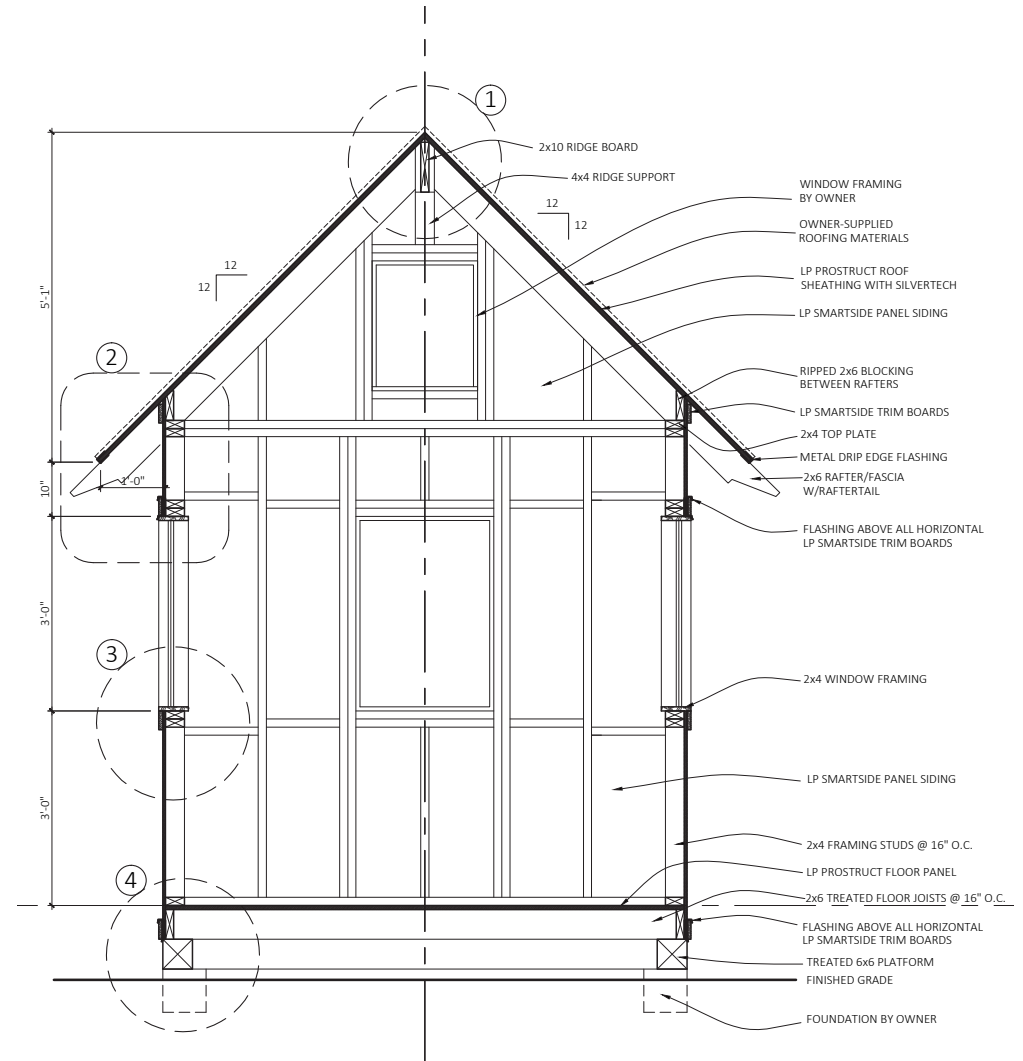

Cross-Section

ROOF DECK

1. We will be using the LP® ProStruct® Roof Sheathing with SilverTech®. Cut sheets as needed to fit the overall size of the roof. Fasten to each roof rafter and outrigger following the roof sheathing installation instructions found at lpcorp.com/resources/product-literature.
2. Depending on the type of roofing finish you put on the shed, follow that roof manufacturer's nailing instruction for proper installation. To accommodate longer recommended nail lengths, you may have to add a layer of 1/2" oriented strand board (OSB) on top of the LP ProStruct Roof Sheathing with SilverTech. Then, install the finished roof and materials as recommended by the manufacturer.

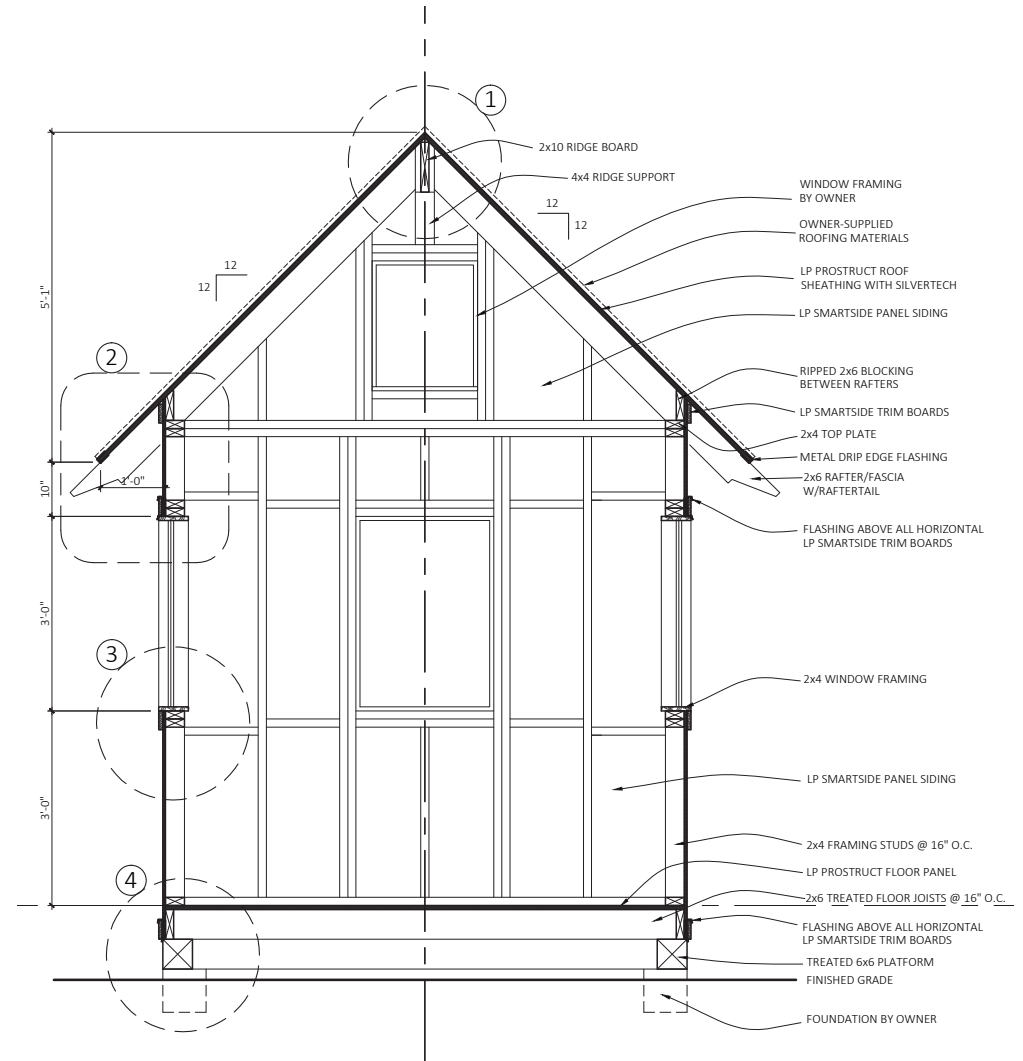

Cross-Section

COMPLETING THE EXTERIOR

1. Re-measure the window and door rough opening, to assure a good fit with the window frame. Adjust your rough framing as needed to properly accept the window and door frames.
2. Install the windows as per the window manufacturer you selected to use. Be sure to include a length of metal flashing along the top of horizontal window trims. Refer also to the Details on the shed plans. Install window hardware.
3. Install the door frame and door as per its manufacturer. Be sure to include a length of metal flashing along the top of horizontal door trims. Shim the frame as needed to assure that it's plumb. Install the doors on their hinges. Install the door hardware.
4. Install the LP® SmartSide® panel siding, along with the LP® SmartSide® trim boards following the LP® SmartSide® installation instructions found at lpcorp.com/resources/product-literature. Use 8" o.c. grooved, vertical panels for the lower section of the gable wall ends, and use 4" o.c. grooved, vertical siding panels above the trim boards to the studs. Be sure to include a length of metal flashing along the top of horizontal trim pieces and panel seams.
5. Finish the exterior of the shed with materials of your choice. Be sure to follow the manufacturer's installation instructions for proper application and maintenance of your finishes.

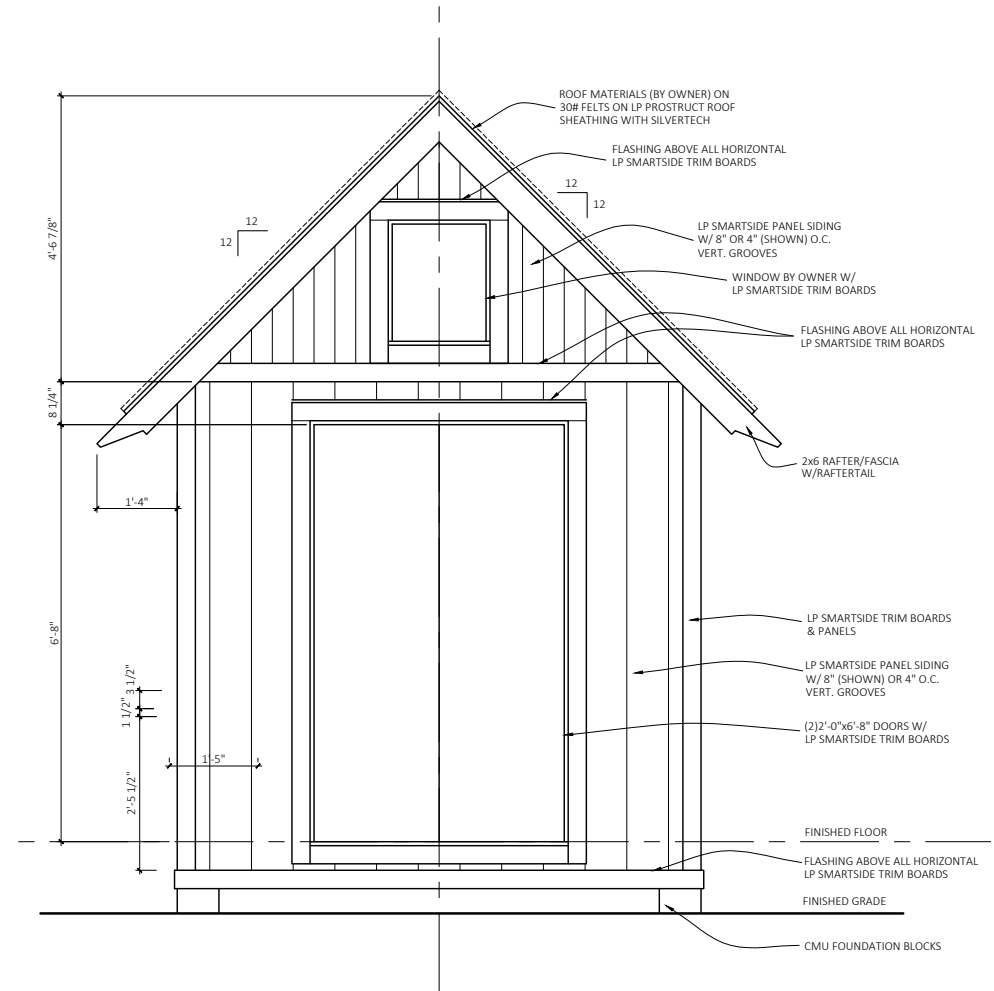

Front Elevation

COMPLETING THE EXTERIOR (CONT.)

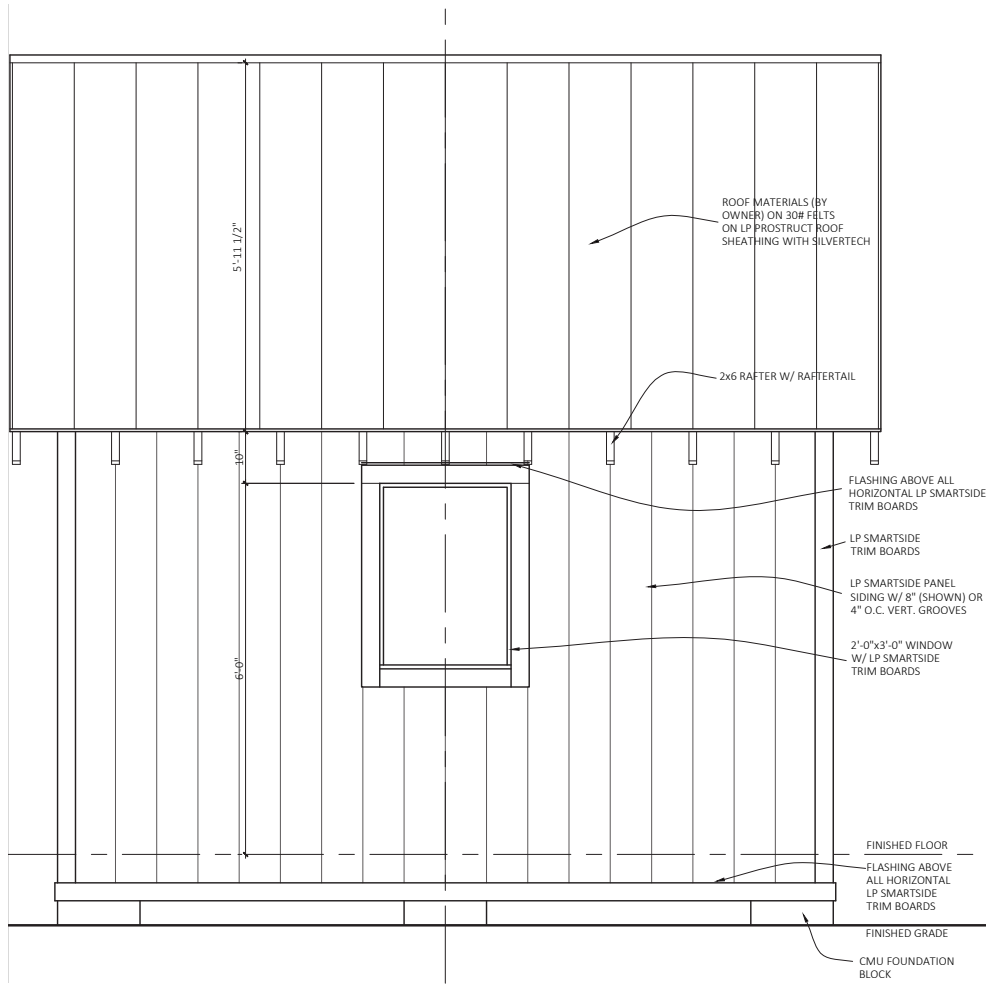

Left & Right Side Elevations

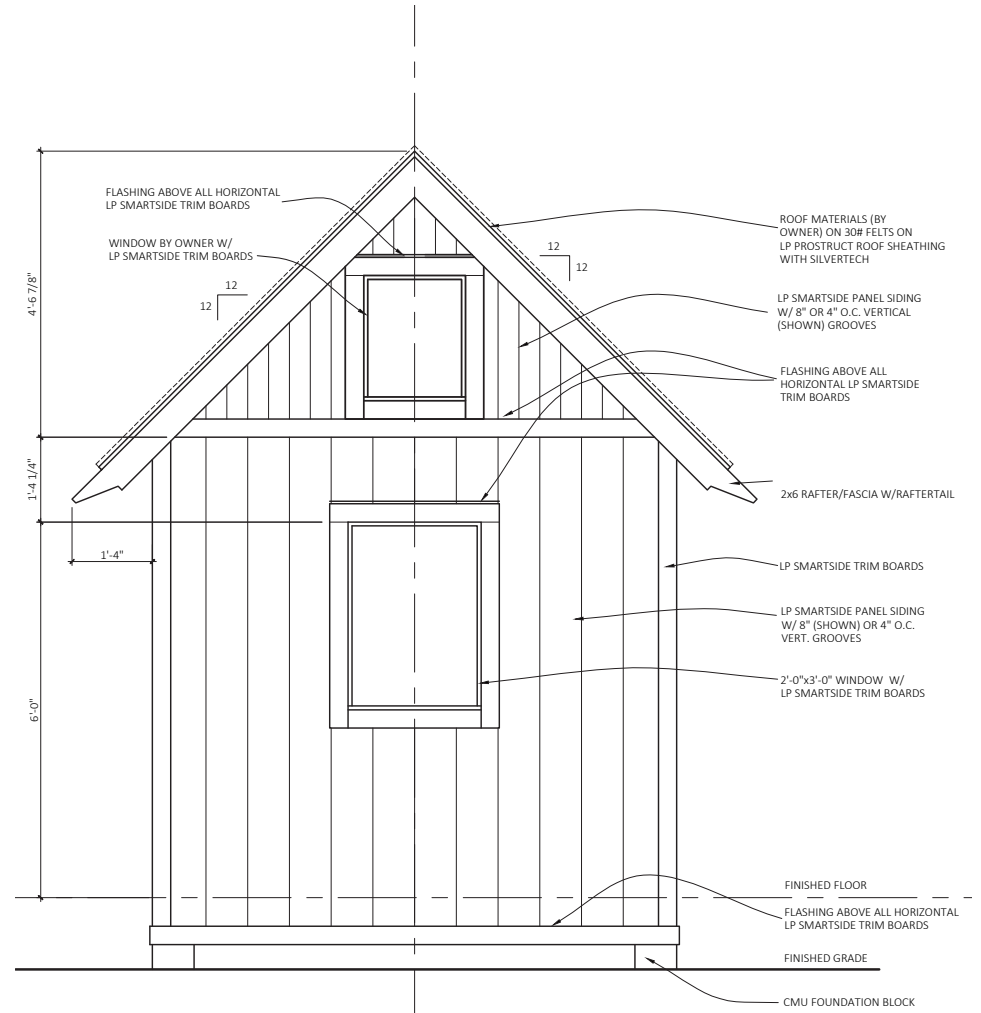

Rear Elevation

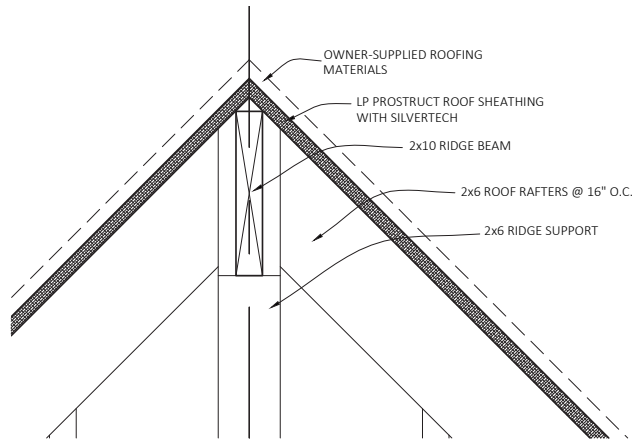

1 Detail @ Ridge

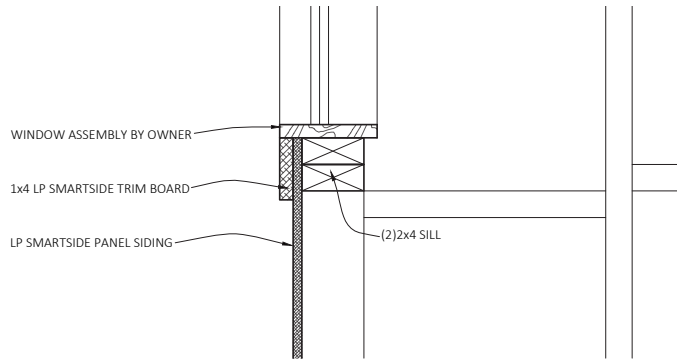

3 Detail

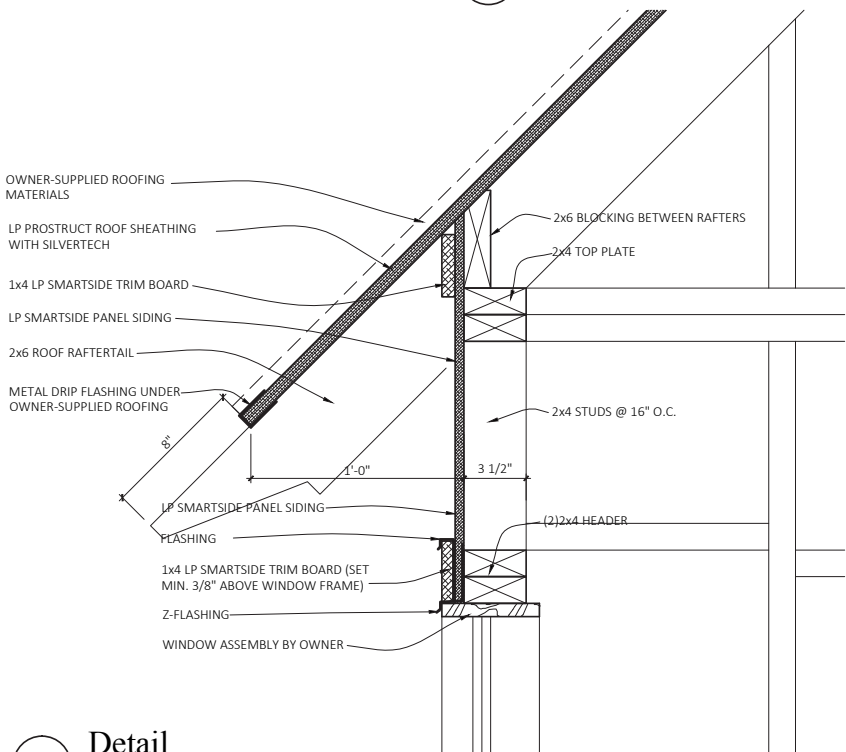

2 Detail

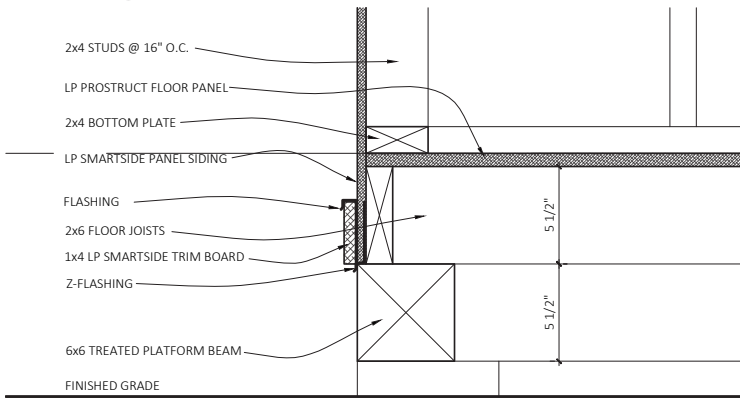

4 Detail

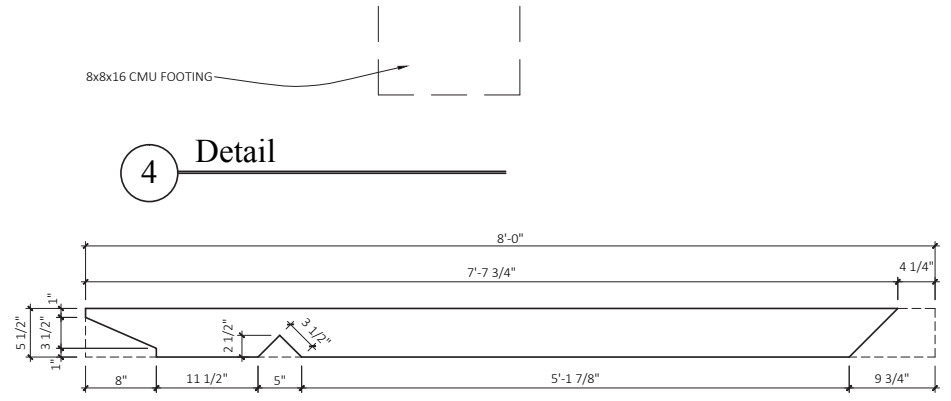

5 Roof Rafter Cuts